

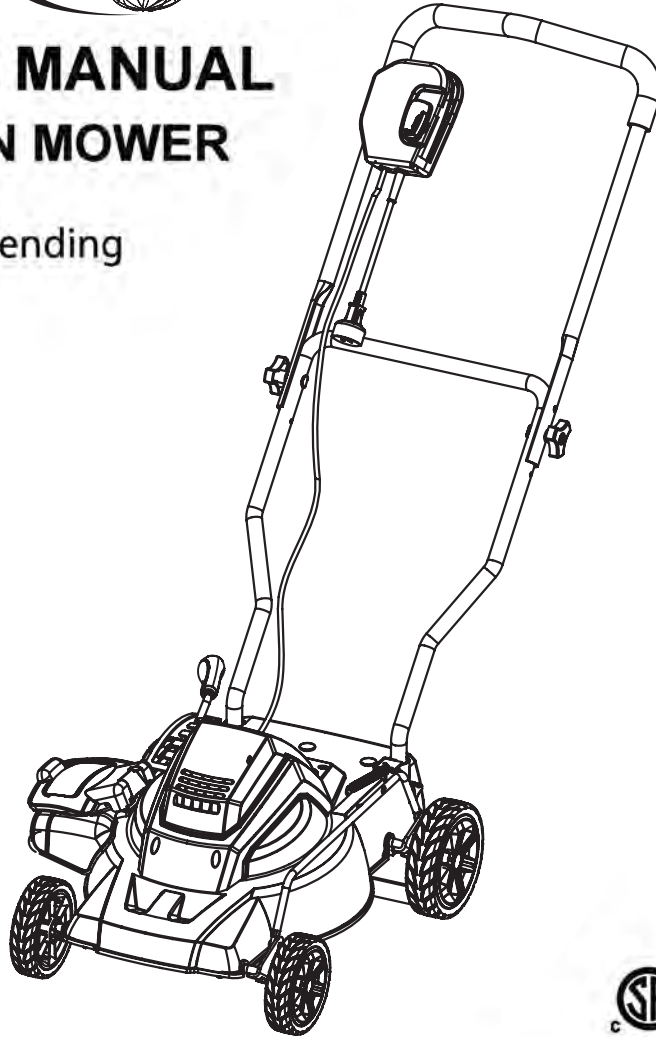

OPERATOR'S MANUAL ELECTRIC LAWN MOWER

United States Patent Pending

14 in.-50214



Your lawn mower has been engineered and manufactured to our high standards for dependability, ease of operation, and operator safety.

WARNING: To reduce the risk of injury, the user must read and understand the operator's manual before using this product.

Thank you for your purchase.

**OPERATING, ASSEMBLY, PARTS, SERVICE QUESTIONS?
DO NOT RETURN THIS PRODUCT TO THE STORE. CALL 1-800-377-5888
BETWEEN 7:30 AM - 4:30 PM EST FOR ASSISTANCE.**

SAVE THIS MANUAL FOR FUTURE REFERENCE

TABLE OF CONTENTS

■ Introduction	2
■ General Safety Rules.....	3-4
■ Specific Safety Rules	4
■ Symbols	5-6
■ Electrical.....	7
■ Features.....	8-9
■ Assembly.....	9-11
■ Operation.....	12-13
■ Maintenance.....	14-16
■ Troubleshooting.....	17
■ Exploded View/Parts List	18
■ Warranty	19
■ Parts Ordering / Service.....	Back Page

INTRODUCTION

This product has many features for making its use more pleasant and enjoyable. Safety, performance, and dependability have been given top priority in the design of this product making it easy to maintain and operate.

GENERAL SAFETY RULES



WARNING:

READ AND UNDERSTAND ALL INSTRUCTIONS.

Failure to follow all instructions listed below and on the machine may result in electric shock, fire, and/or serious personal injury.

READ ALL INSTRUCTIONS

- This lawn mower is capable of amputating hands and feet and throwing objects. Failure to observe all safety instructions could result in serious injury or death.
- Do not use the lawn mower in damp or wet conditions or operate in the rain.
- Never allow adults to operate the product without proper instruction.
- Keep the area clear of all bystanders, children, and pets while mowing. Stop machine if anyone enters the area.
- Tragic accidents can occur if the operator is not alert to the presence of children. Children are often attracted to the machine and the mowing activity. Never assume that children will remain where you last saw them.
 - Keep children out of the mowing area and under the watchful care of a responsible adult other than the operator.
 - Be alert and turn mower off if a child enters the area.
 - Never allow children to operate the lawn mower.
 - Use extra care when approaching blind corners, shrubs, trees, or other objects that may block your view of a child.
- Do not wear loose clothing or jewelry. They can be caught in moving parts. Use of rubber gloves and footwear is recommended when working outdoors.
- Keep firm footing and balance. Do not overreach. Overreaching can result in loss of balance.
- Do not operate the equipment while barefoot or when wearing sandals or similar lightweight footwear. Wear protective footwear that will protect your feet and improve your footing on slippery surfaces.
- Do not leave the mower unattended while running.
- Keep hands and feet away from cutting area. Keep clear of the discharge opening at all times.
- Operate the lawn mower only in daylight or good artificial light.
- Always wear safety glasses with side shields. Everyday glasses have only impact resistant lenses. They are NOT safety glasses. Following this rule will reduce the risk of eye injury. Use face mask if environment is dusty.
- Wear safety glasses or goggles that are marked to comply with ANSI Z87.1 standard when operating this product.
- Use the right appliance. Do not use the lawn mower for any job except that for which it is intended.
- Do not force the lawn mower. It will do the job better and safer at the rate for which it was designed.
- Stay alert, watch what you are doing, and use common sense when operating the lawn mower. Do not operate the mower while tired or under the influence of drugs, alcohol, or medication. A moment of inattention while operating the lawn mower may result in serious personal injury.
- Keep machine in good working condition. Keep blades sharp and guards in place and in working order.
- Check all nuts, bolts, and screws at frequent intervals for proper tightness to be sure the equipment is in safe working condition.
- Stop the motor, disconnect the power cord and wait until the blade comes to a complete stop before cleaning the lawn mower, or unclogging the discharge opening.
- When not in use, mower should be stored indoors in a dry, locked up place—out of the reach of children.
- To reduce the risk of electric shock, this product has a polarized plug (one blade is wider than the other) and will require the use of a polarized extension cord. The plug will fit into a polarized extension cord only one way. If the plug does not fit fully into the extension cord, reverse the plug. If the plug still does not fit, obtain a correct polarized extension cord. A polarized extension cord will require the use of a polarized wall outlet. This plug will fit into the polarized wall outlet only one way. If the plug does not fit fully into the wall outlet, reverse the plug. If the plug still does not fit, contact a qualified electrician to install the proper wall outlet. Do not change the equipment plug, extension cord receptacle, or extension cord plug in any way.
- Do not abuse the cord. Never use the cord to pull the lawn mower or to disconnect the plug from an outlet. Keep cord away from heat, oil, sharp edges, or moving parts. Replace damaged cords immediately. Damaged cords increase the risk of electric shock.
- Make sure your extension cord is in good condition. When using an extension cord, be sure to use one heavy enough to carry the current your product will draw. A wire gauge size (A.W.G.) of at least 14 is recommended for an extension cord 50 feet or less in length. If in doubt, use the next heavier gauge. The smaller the gauge number, the heavier the cord. An undersized cord will cause a drop in line voltage resulting in loss of power and overheating.
- **WARNING:** Use outdoor extension cords marked SW-A, SOW-A, STW-A, STOW-A, SJW-A, SJTW-A, or SJTOWA. These cords are rated for outdoor use and reduce the risk of electric shock.

GENERAL SAFETY RULES







- Ground Fault Circuit Interrupter (GFCI) protection should be provided on the circuit(s) or outlet(s) to be used for the lawn mower. Receptacles are available having built-in GFCI protection and may be used for this measure of safety.
 - Inspect extension cords periodically and replace if damaged. Keep handles dry, clean, and free from oil or grease.
- ⚠WARNING: Some dust and debris created by the use of this tool could contain chemicals known to the State of California to cause cancer and birth defects or other reproductive harm. Some examples of these chemicals are:
- * chemicals in fertilizers
 - * compounds in insecticides, herbicides and pesticides
 - * arsenic and chromium from chemically treated lumber.
- Your risk from exposure to these chemicals varies, depending on how often you do this type of work. To reduce your exposure, work in a well-ventilated area and with approved safety equipment, such as dust masks that are specially designed to filter out microscopic particles.
- ⚠WARNING: The electrical cords on this product may contain chemicals known to the State of California to cause cancer and birth defects or other reproductive harm. Wash hands after handling.

SPECIFIC SAFETY RULES

- Do not operate the mower without the discharge guard, or other safety protective devices in place and working.
- Follow manufacturer's instructions for proper operation and installation of accessories. Only use accessories approved by the manufacturer.
- Clear the work area before each use. Remove all objects such as rocks, sticks, wire, bones, toys, or other objects which can be thrown by the blade. Stay behind the handle when the motor is running.
- Avoid holes, ruts, bumps, rocks, or other hidden objects. Uneven terrain could cause a slip and fall accident.
- Do not mow near drop-offs, ditches, or embankments.
- Mow across the face of slopes, never up and down. Exercise extreme caution when changing direction on slopes.
- Plan your mowing pattern to avoid discharge of material toward roads, sidewalks, bystanders, and the like. Also, avoid discharging material against a wall or obstruction, which may cause the material to ricochet back toward the operator.
- Do not mow on wet grass or excessively steep slopes. Poor footing could cause a slip and fall accident. Walk, never run.
- Use extra care when approaching blind corners, shrubs, trees, or other objects that may block your view.
- Do not pull the mower backward unless absolutely necessary. If you must back the mower away from a wall or obstruction, first look down and behind to avoid tripping.
- Never direct discharged material toward anyone. Avoid discharging material against a wall or obstruction. Material may ricochet back toward the operator. Stop the blade when crossing gravel surfaces.
- Objects struck by the lawn mower blade can cause severe injuries to persons. The lawn should always be carefully examined and cleared of all objects prior to each mowing.
- If the lawn mower strikes a foreign object, follow these steps:
 - Release the switch control lever and stop the lawn mower.
 - Disconnect the power cord.
 - Thoroughly inspect the mower for any damage.
 - Repair any damage before restarting and continuing to operate the mower.
- Stop the motor, disconnect the power cord, and wait until the blade comes to a complete stop before unclogging the discharge guard. The cutting blade continues to rotate for a few seconds after the motor is shut off. Never place any part of the body in the blade area until you are sure the blade has stopped rotating.
- Disconnect the plug from power source before making any adjustments, changing accessories, or storing the lawn mower. Such preventive safety measures reduce the risk of starting the product accidentally.
- If the mower should start to vibrate abnormally, stop the motor and check immediately for the cause. Vibration is generally a warning of trouble.
- Service on the product must be performed by qualified repair personnel only. Service or maintenance performed by unqualified personnel could result in injury to the user or damage to the product.
- Use only identical replacement parts when servicing the product. Use of unauthorized parts may create a risk of serious injury to the user, or damage to the product.
- If the power supply cord is damaged, it must be replaced only by the manufacturer or by an authorized service center to avoid risk.
- Save these instructions. Refer to them frequently and use them to instruct others who may use this product. If you loan someone this lawn mower, loan them these instructions also.



SYMBOLS

Some of the following symbols may be used on this product. Please study them and learn their meaning. Proper interpretation of these symbols will allow you to operate the product better and safer.

SYMBOL	NAME	DESIGNATION/EXPLANATION
V	Volts	Voltage
A	Amperes	Current
Hz	Hertz	Frequency (cycles per second)
W	Watt	Power
hrs	Hours	Time
	Class II Construction	Double-insulated construction
	Wet Conditions Alert	Do not expose to rain or use in damp locations.
	Read The Operator's Manual	To reduce the risk of injury, user must read and understand operator's manual before using this product.
	Eye Protection	Always wear safety goggles or safety glasses with side shields and, as necessary, a full face shield when operating this product.
	Safety Alert	Precautions that involve your safety.
	Electric Shock	Failure to use in dry conditions and to observe safe practices can result in electric shock.

SYMBOLS

The following signal words and meanings are intended to explain the levels of risk associated with this product.

SYMBOL	SIGNAL	MEANING
	DANGER:	Indicates an imminently hazardous situation, which, if not avoided, will result in death or serious injury.
	WARNING:	Indicates a potentially hazardous situation, which, if not avoided, could result in death or serious injury.
	CAUTION:	Indicates a potentially hazardous situation, which, if not avoided, may result in minor or moderate injury.
	CAUTION:	(Without Safety Alert Symbol) Indicates a situation that may result in property damage.

SERVICE

Servicing requires extreme care and knowledge and should be performed only by a qualified service technician. For service we suggest you return the product to your nearest **AUTHORIZED SERVICE CENTER** for repair. When servicing, use only identical replacement parts.



WARNING:

To avoid serious personal injury, do not attempt to use this product until you read thoroughly and understand completely the operator's manual. If you do not understand the warnings and instructions in the operator's manual, do not use this product. Call Earthwise customer service for assistance.



WARNING:



The operation of any power tool can result in foreign objects being thrown into your eyes, which can result in severe eye damage. Before beginning power tool operation, always wear safety goggles or safety glasses with side shields and, when needed, a full face shield. We recommend Wide Vision Safety Mask for use over eyeglasses or standard safety glasses with side shields. Always use eye protection which is marked to comply with ANSI Z87.1.

SAVE THESE INSTRUCTIONS

ELECTRICAL

DOUBLE INSULATION

Double insulation is a concept in safety in electric power tools, which eliminates the need for the usual three-wire grounded power cord. All exposed metal parts are isolated from the internal metal motor components with protecting insulation. Double insulated tools do not need to be grounded.

⚠ WARNING:

The double insulated system is intended to protect the user from shock resulting from a break in the mower's internal insulation. Observe all normal safety precautions to avoid electrical shock.

NOTE: Servicing of a product with double insulation requires extreme care and knowledge of the system and should be performed only by a qualified service technician. For service, we suggest you return the product to your nearest authorized service center for repair. Always use original factory replacement parts when servicing.

ELECTRICAL CONNECTION

This product has a precision-built electric motor. It should be connected to a **power supply that is 120 volts, 60 Hz, AC only (normal household current)**. Do not operate this product on direct current (DC). A substantial voltage drop will cause a loss of power and the motor will overheat. If the product does not operate when plugged into an outlet, double-check the power supply.

EXTENSION CORDS

See Figure 1.

When using a power tool at a considerable distance from a power source, be sure to use an extension cord that has the capacity to handle the current the product will draw. An undersized cord will cause a drop in line voltage, resulting in overheating and loss of power. Use the chart to determine the minimum wire size required in an extension cord. Only round jacketed cords listed by Underwriter's Laboratories (UL) should be used.

When working outdoors with a product, use an extension cord that is designed for outside use. This type of cord is designated with "WA" on the cord's jacket.

Before using any extension cord, inspect it for loose or exposed wires and cut or worn insulation.

It is possible to tie the extension cord and power cord in a knot to prevent them from becoming disconnected during use. Make the knot as shown in figure 1, then connect the plug end of the power cord into the receptacle end of the extension cord. This method can also be used to tie two extension cords together.

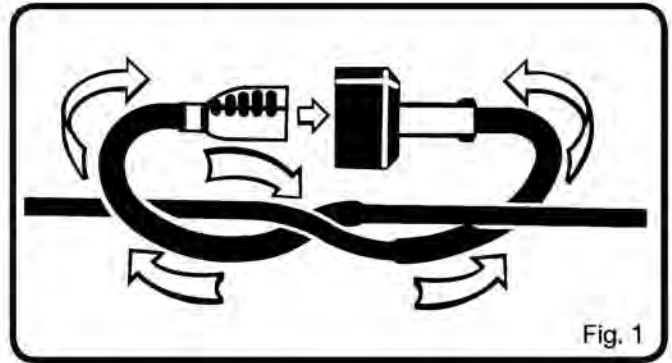

Fig. 1

**Ampere rating (on product data plate)

Cord Length	Wire Size (A.W.G.)					
	0-2.0	2.1-3.4	3.5-5.0	5.1-7.0	7.1-12.0	12.1-16.0
25'	16	16	16	16	14	14
50'	16	16	16	14	14	12
100'	16	16	14	12	12	—

**Used on 12 gauge - 20 amp circuit.

NOTE: AWG = American Wire Gauge

⚠ WARNING:

Keep the extension cord clear of the working area. Position the cord so that it will not get caught on lumber, tools, or other obstructions while you are working with a power tool. Failure to do so can result in serious personal injury.

⚠ WARNING:

Check extension cords before each use. If damaged replace immediately. Never use the product with a damaged cord since touching the damaged area could cause electrical shock resulting in serious injury.

FEATURES

PRODUCT SPECIFICATIONS

50214

Input 120 V, 60 Hz, AC only, 8 Amps

No-load Speed 3,700 r/min. (RPM)

Cutting Path 14 in.

Height Adjustments 1-1/2 in. to 4 in.

Wheel Size 5- 1/2 in. front, 6-1/2 in. rear

Weight 38 lb.

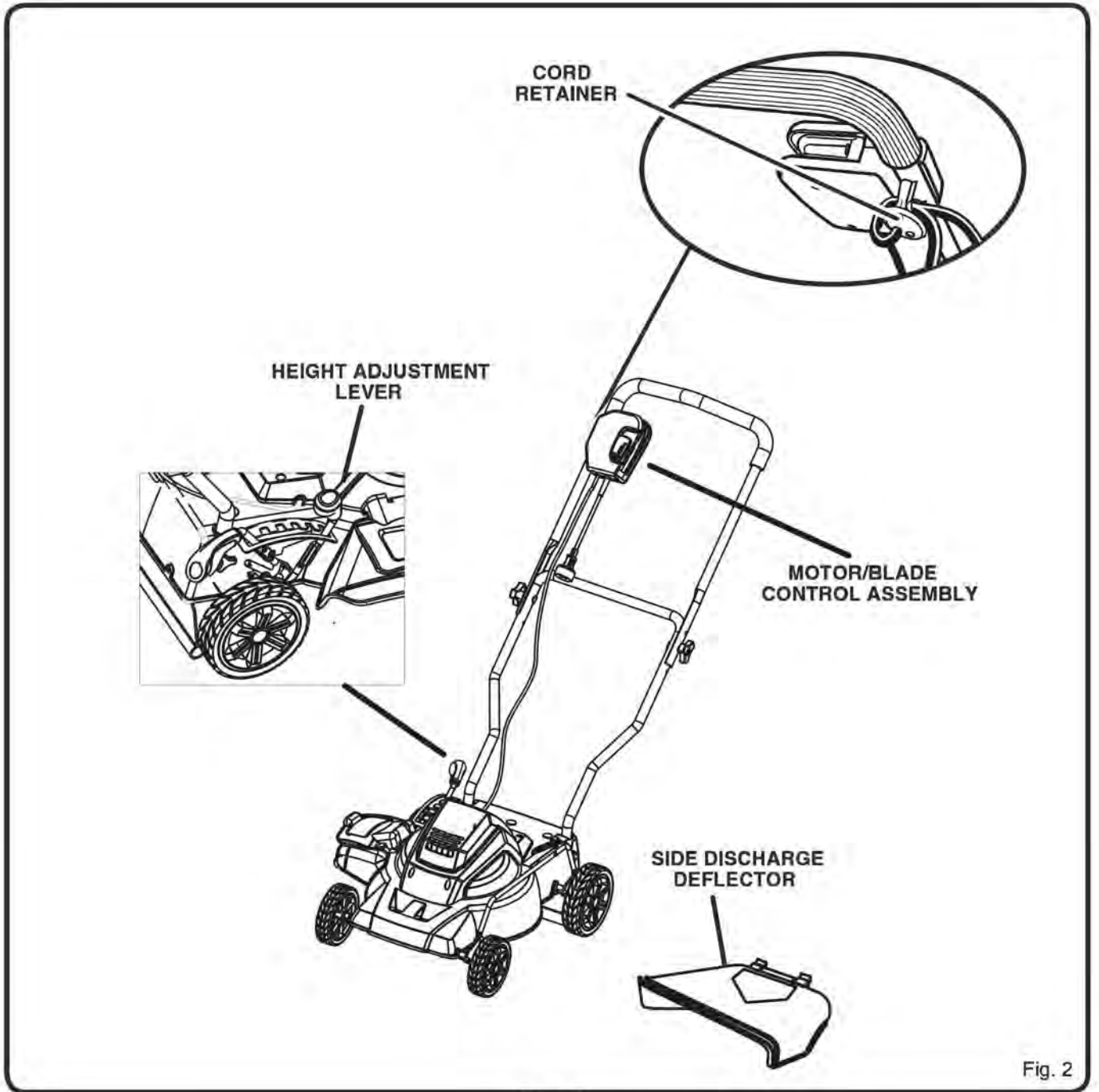

Fig. 2

FEATURES

KNOW YOUR LAWN MOWER

See Figure 2.

The safe use of this product requires an understanding of the information on the product and in this operator's manual as well as a knowledge of the project you are attempting. Before use of this product, familiarize yourself with all operating features and safety rules.

CORD RETAINER

A convenient cord retainer helps keep the extension cord connection secure during mower operation.

HEIGHT ADJUSTMENT LEVER

The height adjustment lever provides cutting height adjustments.

MOTOR/BLADE CONTROL ASSEMBLY

The motor/blade control, located on the upper handle of the mower, engages and disengages the motor and blade.

SIDE DISCHARGE DEFLECTOR

Use the side discharge deflector on your mower when the grass is too high to mulch or when side discharging is preferred. The grass clippings produced when using the side discharge deflector are noticeably larger than those produced when mulching.

ASSEMBLY

UNPACKING

This product requires assembly.

- Carefully remove the product and any accessories from the box. Make sure that all items listed in the packing list are included.
- Inspect the product carefully to make sure no breakage or damage occurred during shipping.
- Do not discard the packing material until you have carefully inspected and satisfactorily operated the product.
- If any parts are damaged or missing, please call 1-800-377-5888 for assistance.

PACKING LIST

Mower
Side Discharge Deflector
Operator's Manual

WARNING:

If any parts are damaged or missing do not operate this product until the parts are replaced. Failure to heed this warning so could result in serious personal injury.

WARNING:

Do not attempt to modify this product or create accessories not recommended for use with this product. Any such alteration or modification is misuse and could result in a hazardous condition leading to possible serious personal injury.

WARNING:

Do not connect to power supply until assembly is complete. Failure to comply could result in accidental starting and possible serious personal injury.

ASSEMBLY

WARNING:

Never operate the mower without the proper safety devices in place and working. Never operate the mower with damaged safety devices. Failure to heed this warning can result in serious personal injury.

ADJUSTING HANDLE

See Figure 3.

- Adjust the blade to the highest position.
- Insert lower handle into sockets at the rear of the deck.
- Secure lower handle to the deck with knobs.
- Connect upper handle to lower handle with handle knobs on both sides.

INSTALLING SIDE DISCHARGE DEFLECTOR

See Figure 4.

- Lift the side discharge door.
- Align the grooves on the deflector with the pins on the underside of the door.
- Lower the deflector until the hooks on the mower deck are secured in the openings in the deflector.
- Release the deflector and door.

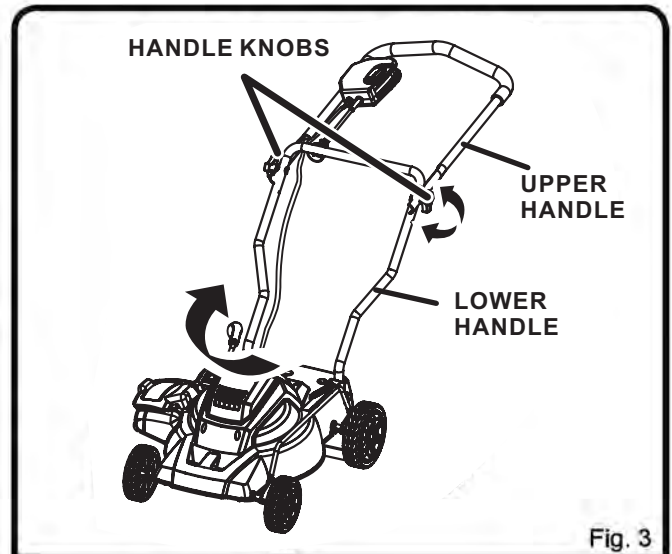
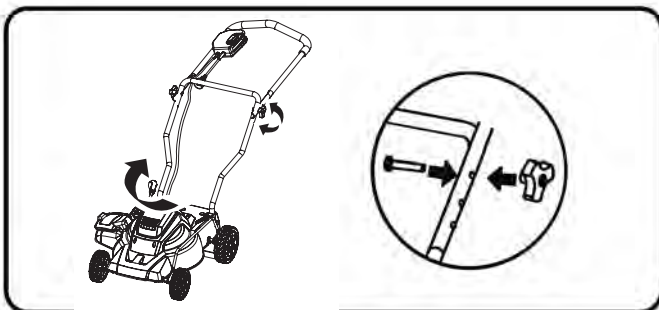

Fig. 3

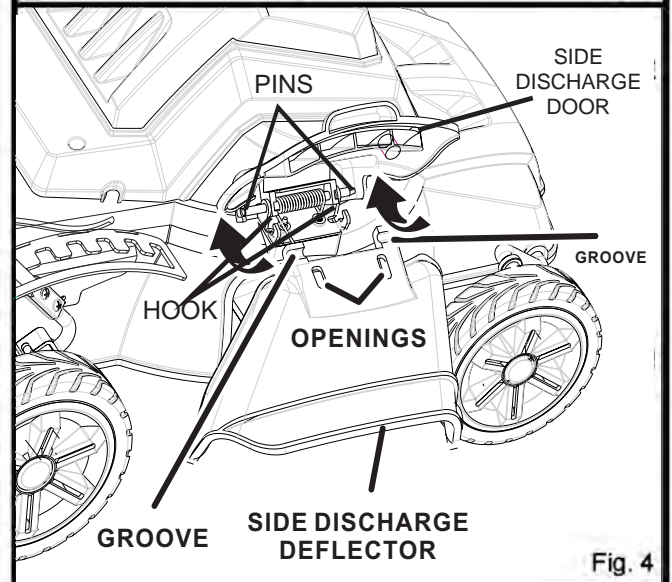

Fig. 4

ASSEMBLY

SETTING BLADE HEIGHT

See Figure 5.

When shipped, the wheels on the mower are set to a low-cutting position. Before using the mower for the first time, adjust the cutting position to the height best suited for your lawn. The average lawn should be between 1-1/2 in. to 2 in. during cool months and between 2 in. and 3-1/4 in. during hot months.

To set the blade height:

- To raise the blade height, grasp the height adjustment lever and move it toward the back of the mower.
- To lower the blade height, grasp the height adjustment lever and move it toward the front of the mower.

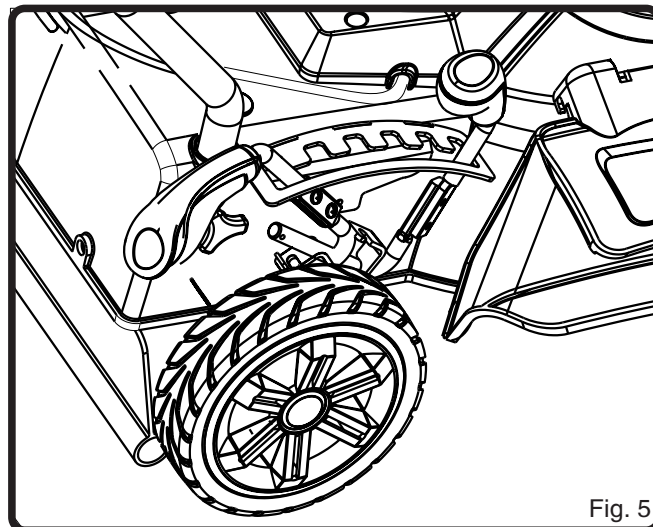

Fig. 5

OPERATION

WARNING:

Do not allow familiarity with this type of product to make you careless. Remember that a careless fraction of a second is sufficient to inflict serious injury.

WARNING:

Always wear safety goggles or safety glasses with side shields when operating this product. Failure to do so could result in objects being thrown into your eyes, resulting in possible serious injury.

WARNING:

Do not use any attachments or accessories not recommended by the manufacturer of this product. The use of attachments or accessories not recommended can result in serious personal injury.

APPLICATIONS

You may use this product for the purpose listed below:

- Mowing your lawn

STARTING/STOPPING THE MOWER

See Figure 6.

- Attach the outlet end of an extension cord to the plug on the rear of the mower.

NOTE: Use only an approved outdoor extension cord as described previously in this manual.

- Make a loop in the extension cord. From the right side, pass the loop through the hole in the back of cord retainer and place it around the hook.
- Rotate the lever release counterclockwise and hold to allow access to the switch control lever.
- Pull the switch control lever toward the mower handle and let go of the lever release. Continue to hold the switch control lever against the mower handle as you mow.
- To stop the mower, release the switch control lever.

NOTE: A high-pitched noise and sparking may occur as the electric motor decelerates. This is normal.

MOWING TIPS

See Figure 7.

- Make sure the lawn is clear of stones, sticks, wires, and other objects that could damage the lawn mower blades or motor. Such objects could be accidentally thrown by the mower in any direction and cause serious personal injury to the operator and others.
- To reduce the likelihood of disconnecting the lawn mower from the extension cord, be sure to use the cord retainer provided.

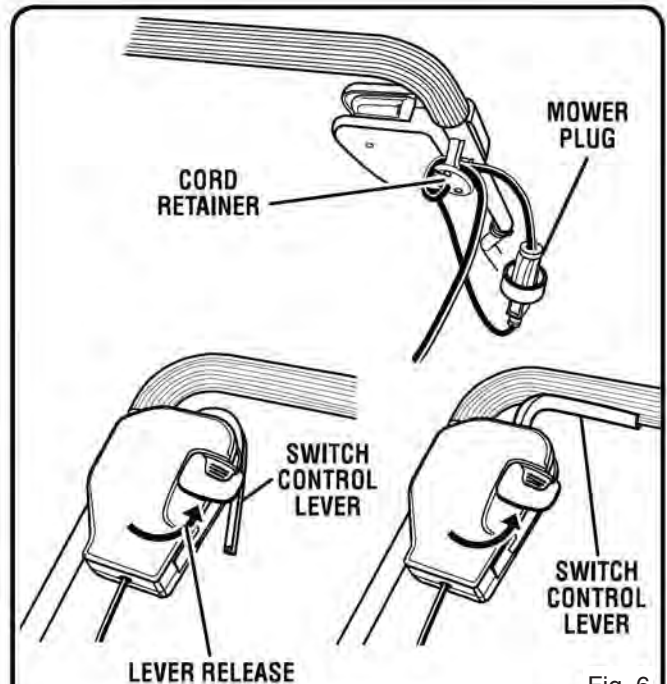

Fig. 6

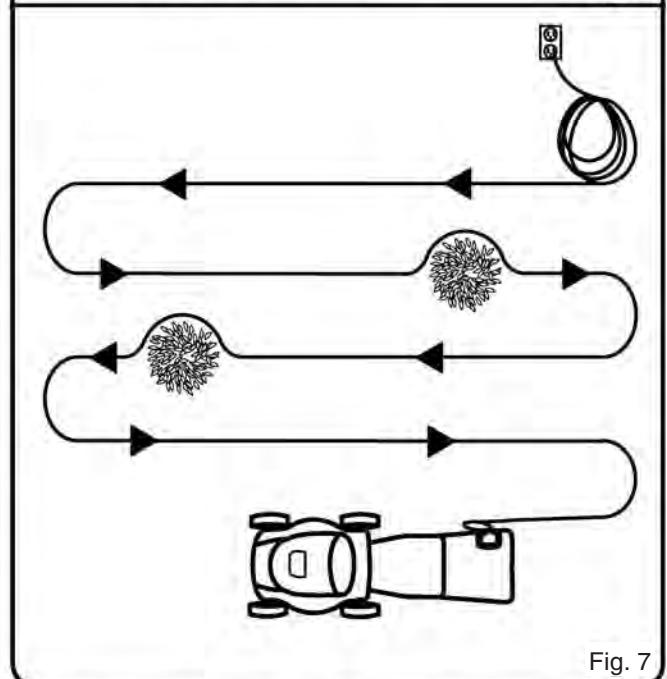

Fig. 7

- Do not mow in circles. Start from the point closest to the outlet and travel back and forth across the lawn, moving away from the outlet so the cord remains behind the mower in the cut portion of the lawn.
- Do not allow the extension cord to wrap around trees, shrubs, or other obstacles. When picking up the extension cord, wind the cord in a series of equal loops to prevent it from tangling.

OPERATION

- For a healthy lawn, always cut off one-third or less of the total length of the grass.
- When cutting heavy grass, reduce walking speed to allow for more effective cutting and a proper discharge of the clippings.
- Do not cut wet grass. It will stick to the underside of the deck and prevent proper mulching of grass clippings.
- New or thick grass may require a narrower cut.
- Clean the underside of the mower deck after each use to remove grass clippings, leaves, dirt, and any other accumulated debris. Always unplug cord from electrical outlet prior to cleaning.

SLOPE OPERATION

See Figure 8.

- Slopes are a major factor related to slip and fall accidents that can result in severe injury. Operation on slopes requires extra caution. If you feel uneasy on a slope, do not mow it. For your safety, do not attempt to mow slopes greater than 15 degrees.
- Mow across the face of slopes, not up and down. Exercise extreme caution when changing direction on slopes.
- Watch for holes, ruts, rocks, hidden objects, or bumps which can cause you to slip or trip. Tall grass can hide obstacles. Remove all objects such as rocks, tree limbs, etc., which could be tripped over or thrown by the blade.
- Always be sure of your footing. A slip and fall can cause serious personal injury. If you feel you are losing your balance, release the switch control lever immediately.
- Do not mow near drop-offs, ditches, or embankments; you could lose your footing or balance.

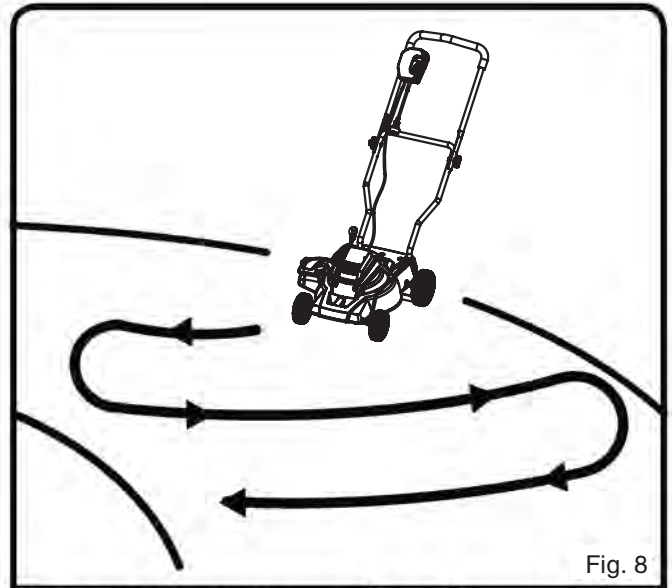

Fig. 8

MAINTENANCE

⚠ WARNING:

When servicing, use only identical replacement parts. Use of any other parts may create a hazard or cause product damage.

⚠ WARNING:

Always wear safety goggles or safety glasses with side shields during power tool operation or when blowing dust. If environment is dusty, also wear a dust mask.

GENERAL MAINTENANCE

Avoid using solvents when cleaning plastic parts. Most plastics are susceptible to damage from various types of commercial solvents and may be damaged by their use. Use clean cloths to remove dirt, dust, oil, grease, etc.

⚠ WARNING:

Do not at any time let brake fluids, gasoline, petroleum-based products, penetrating oils, etc., come in contact with plastic parts. Chemicals can damage, weaken, or destroy plastic which may result in serious personal injury.

Periodically check all nuts and bolts for proper tightness to ensure safe operation of the mower.

Remove any buildup of grass and leaves on or around the motor cover. Wipe the mower clean with a dry cloth occasionally. **Do not use water.**

LUBRICATION

All of the bearings in this product are lubricated with a sufficient amount of high grade lubricant for the life of the unit under normal operating conditions. Therefore, no further bearing lubrication is required.

At the beginning and end of each mowing season:

- Lubricate the height adjustment lever and related hardware with light oil.
- Remove the wheels and lubricate the surface of the axle bolt and the inner surface of the wheel with light oil.
- Remove the blade and blade hub assembly and lubricate the motor shaft with light oil or engine oil. See **Replacing the Cutting Blade** for instructions on removing the blade.

⚠ WARNING:

Always protect hands by wearing heavy gloves and/or wrapping the cutting edges of the blade with rags and other material when performing blade maintenance. Failure to heed this warning could result in serious personal injury.

⚠ WARNING:

Before performing any maintenance, make sure the mower is unplugged from the power supply. Failure to heed this warning could result in serious personal injury.

REPLACING THE CUTTING BLADE

See Figures 9–10.

NOTE: Only use identical replacement blades.

- Stop the motor and disconnect the power supply. Allow the blade to come to a complete stop.
- Turn the mower on its side.
- Wedge a block of wood between the blade and mower deck to prevent the blade from turning.
- Loosen the blade nut using a 15 mm wrench or socket (not provided).
- Remove the blade nut, spacer, blade insulator, and blade.
- Make certain the fan assembly is pushed completely against the motor shaft.

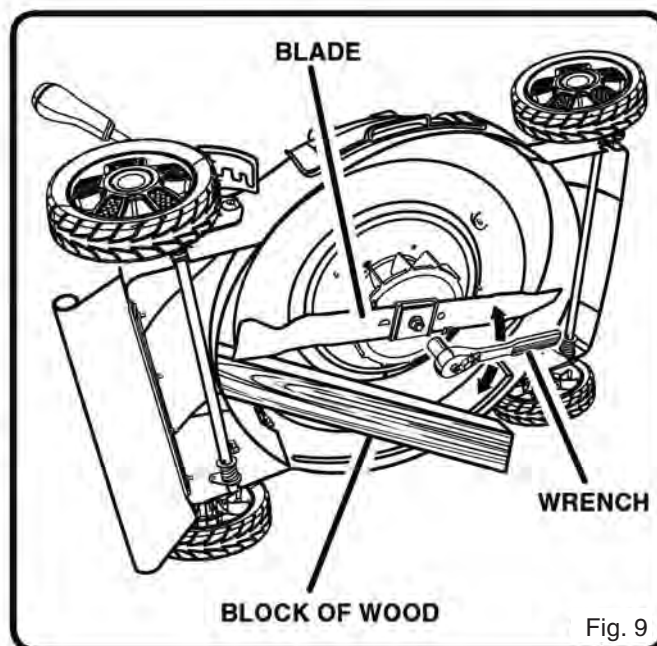

MAINTENANCE

- Place the new blade on the shaft against the fan assembly. Make sure it is installed with the curved ends pointing up toward the mower deck and not down toward the ground.
- Replace the blade insulator and spacer, then thread the blade nut on the shaft and finger tighten.
NOTE: Make certain all parts are replaced in the exact order in which they were removed.
- Torque the blade nut down using a torque wrench (not provided) to ensure the bolt is properly tightened. The recommended torque for the blade nut is 220-310 in. lbs.

SHARPENING THE BLADE

See Figure 11.

For best mowing performance, the mower blade must be kept sharp. A dull blade does not cut grass evenly and overloads the motor. Under normal circumstances, sharpening the blade twice during the mowing season is usually sufficient. However, if your lawn has sandy soil, more frequent sharpenings may be required.

- Following the instructions in the **Replacing the Cutting Blade** section, remove the mower blade. DO NOT attempt to sharpen the blade while it is attached to the mower.

WARNING:

When removing, inspect the blade carefully. If blade is bent or damaged, replace immediately with a new blade. Failure to replace a bent or damaged blade could cause an accident resulting in possible serious injury.

- Using a fine-tooth file or stone, sharpen cutting edges on both ends of the blade, removing equal amounts of material from both ends.

BALANCING THE BLADE

See Figure 12.

When sharpening, care should be taken to keep the blade balanced. An unbalanced blade will cause excessive vibration when the mower is running. This vibration will eventually cause damage to the mower, especially the motor.

To check the blade balance:

- Clamp a screwdriver horizontally in a vise as shown.
NOTE: If a vise is not available, a straight nail can also be used.
- Place the center hole of blade on the screwdriver (or nail) shank.
- If blade is balanced, it will remain in a horizontal position. If either end of the blade drops downward, sharpen the heavy side until the blade is balanced.

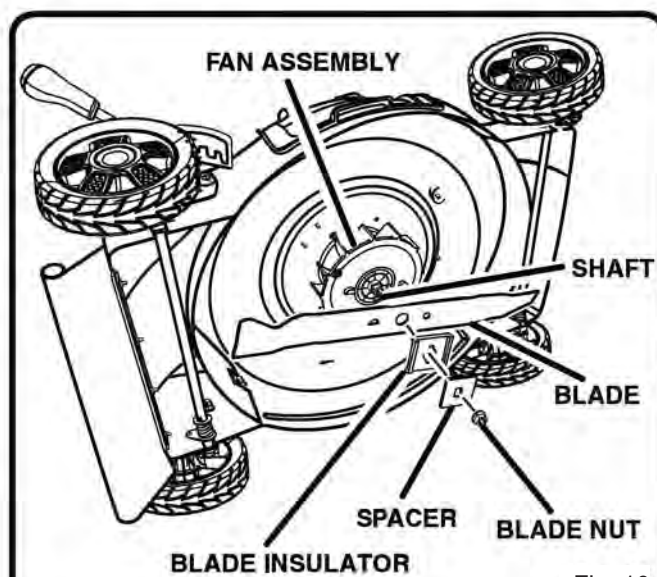

Fig. 10

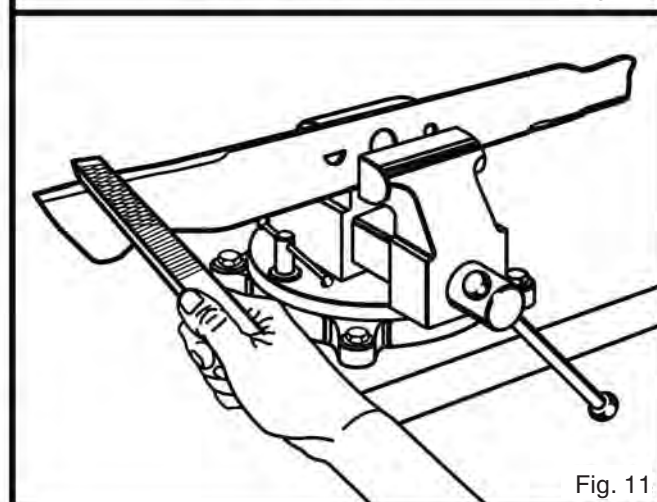

Fig. 11

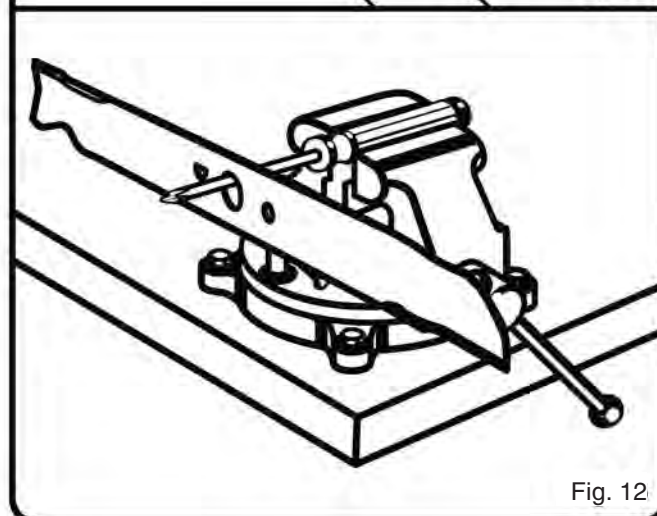

Fig. 12

MAINTENANCE

REPLACING WHEELS

See Figure 13.

To replace a wheel:

- Disconnect the mower from the power supply.
- Turn the mower on its side.
- Using a flat blade screwdriver, pry off the hubcap.
- Remove the screw and gasket from the wheel axle, then remove the wheel.
- Replace with new wheel and use new screw and gasket to secure.
- Replace hubcap.

STORING THE MOWER

See Figure 14.

- Disconnect the mower from the power supply.
- Turn mower on its side and clean grass clippings that have accumulated on the underside of the mower deck.
- Wipe the mower clean with a dry cloth.
- Check all nuts, bolts, knobs, screws, fasteners, etc., for tightness.
- Inspect moving parts for damage, breakage, and wear. Have repairs made on any damaged or missing parts.
- Store mower indoors in a clean, dry place out of the reach of children.
- Do not store near corrosive materials such as fertilizer or rock salt.

To lower the handle before storing:

- Fully loosen the handle knobs on the sides of the handle and fold the upper handle down.
- Fully loosen the knobs at both sides of the deck and remove lower handle from the sockets.
- Place folded handles on mower, making sure not to bend or kink the power cord.

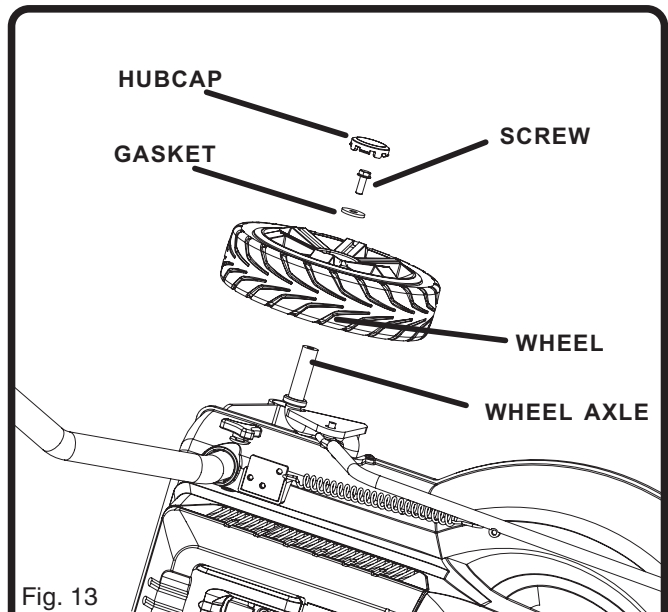

Fig. 13

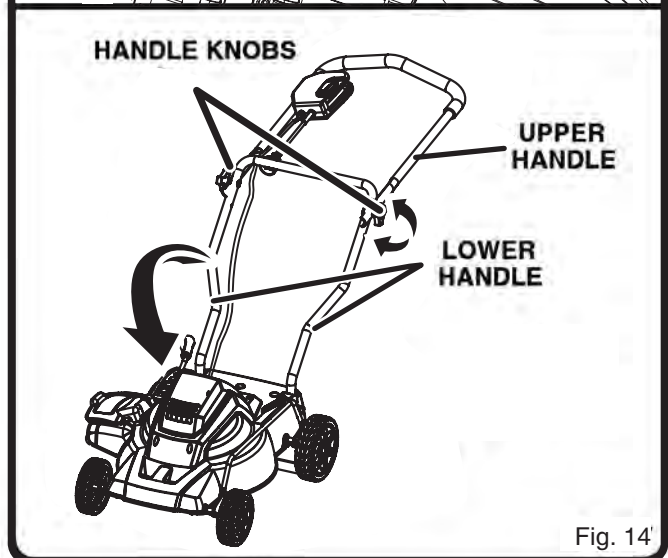

Fig. 14

WARNING:

USE EXTREME CAUTION WHEN FOLDING THE HANDLE. THE CORD CAN BE DAMAGED IF PINCHED BETWEEN HANDLE SECTIONS CREATING A SAFETY HAZARD.

TROUBLESHOOTING

Problem	Possible Cause	Solution
Handle not in position.	Carriage bolts not seated properly. Handle knobs not tightened.	Adjust the height of the handle and make sure the carriage bolts are seated properly. Tighten handle knobs.
Mower not starting.	Extension cord not connected to the mower plug. Extension cord not connected to power source. Tripped circuit breaker in the house. Motor control switch defective.	Reconnect the cord and use the cord retainer to keep the cord close to the motor/blade control. Connect the extension cord to a live 120V AC, 60 HZ AC receptacle. Reset house circuit breaker. If it trips again, call a qualified electrician. Have motor control switch replaced by an authorized service center.
Mower cutting grass unevenly.	Lawn is rough or uneven or cutting height not set properly.	Move the wheels to a higher position.
Mower not mulching properly.	Wet grass clippings sticking to the underside of the deck.	Wait until the grass dries before mowing.
Mower hard to push.	High grass, rear of mower housing and blade dragging in heavy grass, or cutting height too low.	Raise cutting height.
Mower vibrating at higher speed.	Blade is unbalanced. Bent motor shaft.	Balance the blade by grinding each cutting edge equally. Stop the motor, disconnect the power source, and inspect for damage. Have repaired by an authorized service center before restarting.



CALL US FIRST

For any questions about operating or maintaining your product, call the Earthwise™ Help Line!

1-800-377-5888

Your product has been fully tested prior to shipment to ensure your complete satisfaction.

EXPLODED VIEW/PARTS LIST

MODEL 50214

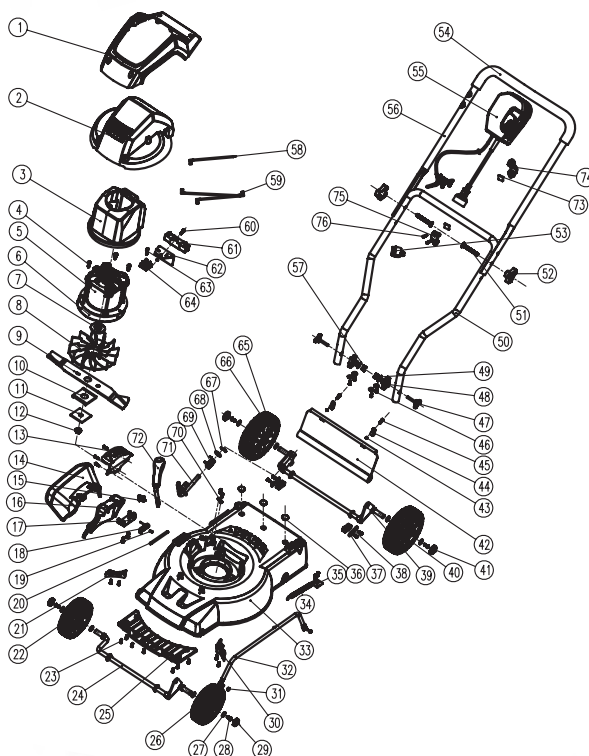

Key No.	Part No.	Description	Qty.	Key No.	Part No.	Description	Qty.
1	8006-516602	motor vent	1	39	8440-516702	rear wheel axle	1
2	8006-516601	motor cover	1	40	8121-516704	left rear wheel	1
3	8006-516603	motor housing	1	41	8021-516702	wheel cover	2
4	8SJGN50-25Q	self-tapping screw	3	42	8181-516701	rear flap	1
5	8401-516601	motor	1	43	8NG-04QQ18.8	self-locking nut	3
6	8336-517101	shock pad	1	44	8186-517002	chip	2
7	8224-516202	spindle guard	1	45	8SJGN04-20Q	screw	2
8	8403-517001	fan	1	46	8WE-04B	washer	4
9	8231-517001	blade	1	47	8313-516601	knob	2
10	8181-517002	blade insulator	1	48	8313-516602	lock knob	2
11	8321-517006	spacer	1	49	8325-532403	washer	4
12	8207-517001	blade nut	1	50	8001-516702	lower handle	1
13	8440-516703	height adjustment bracket right	1	51	8206-517001	bolt	2
14	8020-517003	side discharge deflector	1	52	8313-513701	knob	2
15	8SJAD05-12Q8.8	machine screw	2	53	8007-517001	cord guide	2
16	8006-516708	side discharge door	1	54	8331-516201	grip	1
17	8321-516701	side discharge bracket	1	55	8000-516002	switch and power cable assy	1
18	8342-516703	compression spring	1	56	8001-516703	upper handle with soft grip	1
19	8025-516205	rubber cap	2	57	8SNAB30-06Q	self-tapping screw	4
20	8081-516204	side discharge pin	1	58	8413-517001	connection wire 1	1
21	8006-516709	right insert plate	1	59	8413-517002	connection wire 2	1
22	8121-516701	front right wheel	1	60	8SJGN04-10Q	machine screw	1
23	8SJAB40-14Q	self-tapping screw	38	61	8417-516201	resistance	1
24	8440-516701	front wheel axle	1	62	8183-516601	resistance heat sink	1
25	8006-516706	deck board	1	63	8SJAB50-16Q	self-tapping screw	1
26	8121-516703	front left wheel	1	64	8202-517201	washer	8
27	8321-516710	gasket	4	65	8121-516702	rear right wheel	1
28	8SJGD06-12Q	screw	6	66	8427-517001	electrical bridge	1
29	8021-516701	wheel cover	2	67	8CC-10B	washer	1
30	8006-516710	left insert plate	1	68	8321-516712	washer	1
31	8NH-06D8.8	self-locking nut	4	69	8342-516704	extension spring	1
32	8087-516701	link bar	1	70	8184-516201	power cord clamp plate	1
33	8087-516701	deck	1	71	8347-516702	height adjustment handle bar	1
34	8342-516601	extension spring	1	72	8087-516702	height adjustment handle	1
35	8321-516709	spring pad	1	73	8336-516411	gasket	2
36	8348-516601	rubber cap	3	74	8007-516401	cord guide upper cover	1
37	8WF-04Q	washer	4	75	8007-516402	cord guide lower cover	1
38	8301-514401	axle press board	2	76	8SJAB30-16B	self-tapping screw	1

WARRANTY

LIMITED WARRANTY FOR CORDED ELECTRIC MODELS.

This product is manufactured for the American Lawn Mower Company/Great States Corporation. American Lawn Mower Company/Great States Corporation, Shelbyville, Indiana, has been making lawn mowers for over 100 years and it warrants to the original owner that each new product and service part is free from defects in material and workmanship and agrees to repair or replace under this warranty any defective product or part from the original date of purchase for two (2) years except for the conditions and circumstances listed below. Proof of purchase (original dated sales receipt) must accompany all warranty claims.

THIS WARRANTY IS NOT TRANSFERABLE AND DOES NOT COVER:

- Products sold damaged or incomplete, sold “as is”, sold reconditioned, or used as rental equipment.
- Delivery, installation, or normal adjustments explained in the operator’s manual.
- Damage or liability caused by shipping, improper handling, improper installation, incorrect voltage or improper wiring, improper maintenance, improper modification, or the use of accessories and/or attachments not specifically recommended.
- Repairs necessary because of operator abuse or negligence, or the failure to install, operate, maintain, and store the product according to the instructions in the operator’s manual.
- Damage caused by cold, heat, rain, excessive humidity, corrosive environments and materials, or other contaminants.
- Expendable items that become worn during normal use.
- Cosmetic defects that do not interfere with tool functionality.
- Freight costs from customer to vendor.

Repair and transportation costs of products or parts determined not to be defective.

- ANY INCIDENTAL, INDIRECT, OR CONSEQUENTIAL LOSS, DAMAGE, OR EXPENSE THAT MAY RESULT FROM ANY DEFECT, FAILURE, OR MALFUNCTION OF THE PRODUCT. Some states do not allow the exclusion or limitation on how long an implied warranty lasts, so the above limitations may not apply to you.
- ANY NON-RESIDENTIAL USE OR COMMERCIAL USE VOIDS ALL WARRANTIES.

CALL US FIRST !!

Call us first with questions about operating or maintaining your lawn mower at 1-800-377-5888 between 7:30 a.m. – 4:30 p.m. Eastern Standard Time, or send emails to earthwise@reelin.com.



OPERATOR'S MANUAL

ELECTRIC LAWN MOWER

United States Patent Pending

14 in.-50214

SERVICE

For parts or service, contact your nearest Earthwise authorized service dealer. Be sure to provide all relevant information when you call or visit. For the location of the authorized service dealer nearest you, please call 1-800-377-5888 or visit us online at www.reelin.com/earthwise.

REPAIR PARTS

The model number of this tool is found on a plate or label attached to the housing. Please record the serial number in the space provided below.

MODEL NUMBER 50214

SERIAL NUMBER _____



830 Webster Street
Shelbyville, IN 46176
Phone 1-800-377-5888
www.reelin.com/earthwise